

LETTER	NAME
A	OIL FILTER, ENGINE
B	OIL FILL, ENGINE
C	OIL DRAIN, ENGINE
D	OIL DIPSTICK, ENGINE
E	RAW WATER PUMP
F	LIFTING EYE
G	FUEL CONNECTION, I.D. 9,5 [3/8] NPT OR 6,35 [1/4] NPT
H	FUEL FILTER
I	ELECTRICAL FUEL PUMP
J	THROTTLE CABLE NON EVC
K	WATER COOLED EXHAUST PIPE
L	STARTER MOTOR
M	FUSE PANEL
N	ELECTRICAL CONNECTION ENGINE - INSTRUMENT PANEL
O	CIRCUIT BREAKER FOR TRIM PUMP
P	OIL FILL, POWER STEERING
R	STEERING CABLE
S	WATER INTAKE
T	OIL FILL, DRIVE UNIT
U	OIL DRAIN, DRIVE UNIT
V	OIL DIPSTICK, DRIVE UNIT
X	SEE INSTALLATION INSTRUCTIONS
Y	COOLANT FILL AND LEVEL CHECK
Z	ENGINE FLUSH
AC	ANODE, EXHAUST MANIFOLDS (BOTH SIDES)
AB	EASY DRAIN-VALVE
AD	EASY DRAIN HANDLE OPEN/CLOSE
AE	AUXILIARY STOP
AF	EXTERNAL ENGINE FLUSH

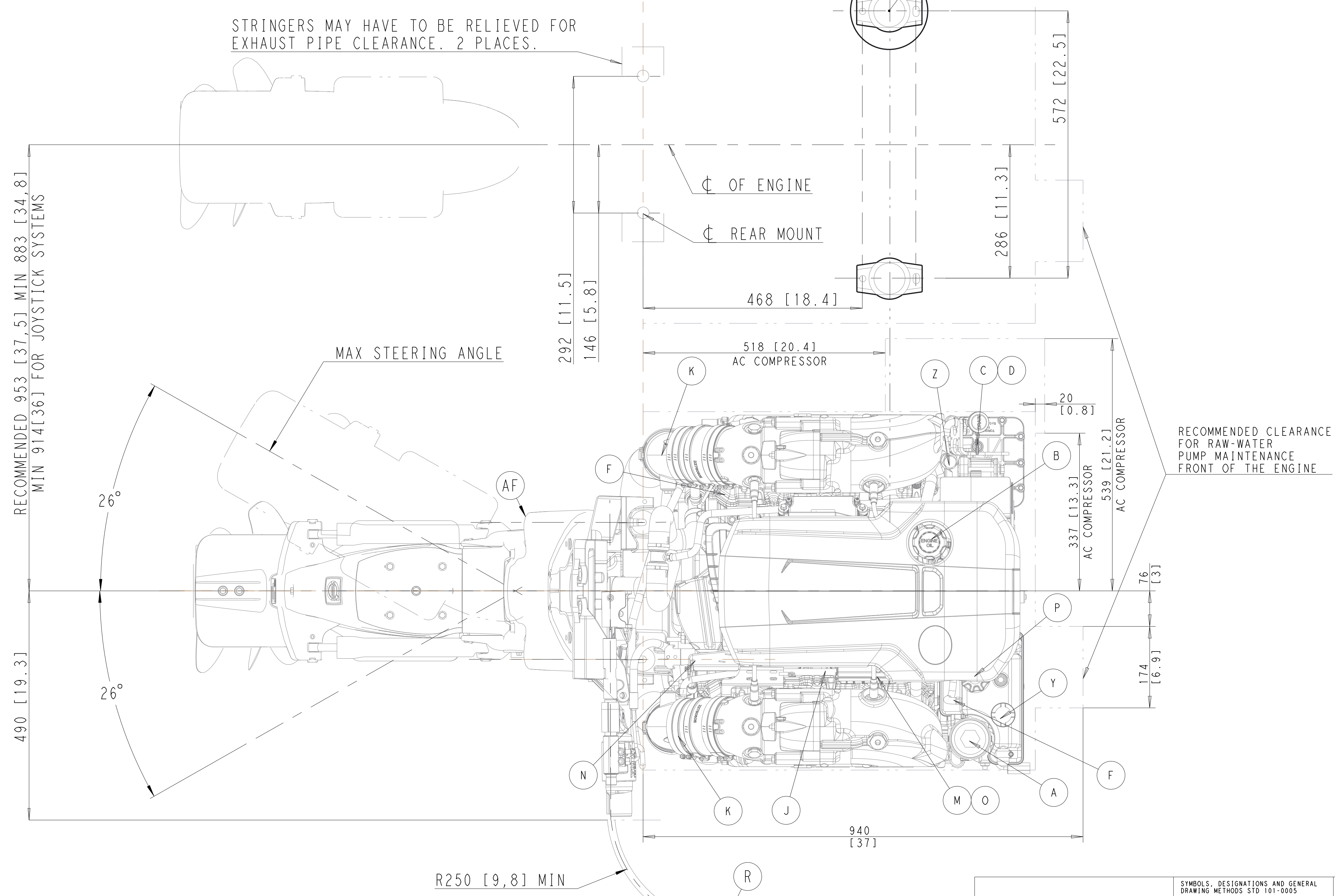
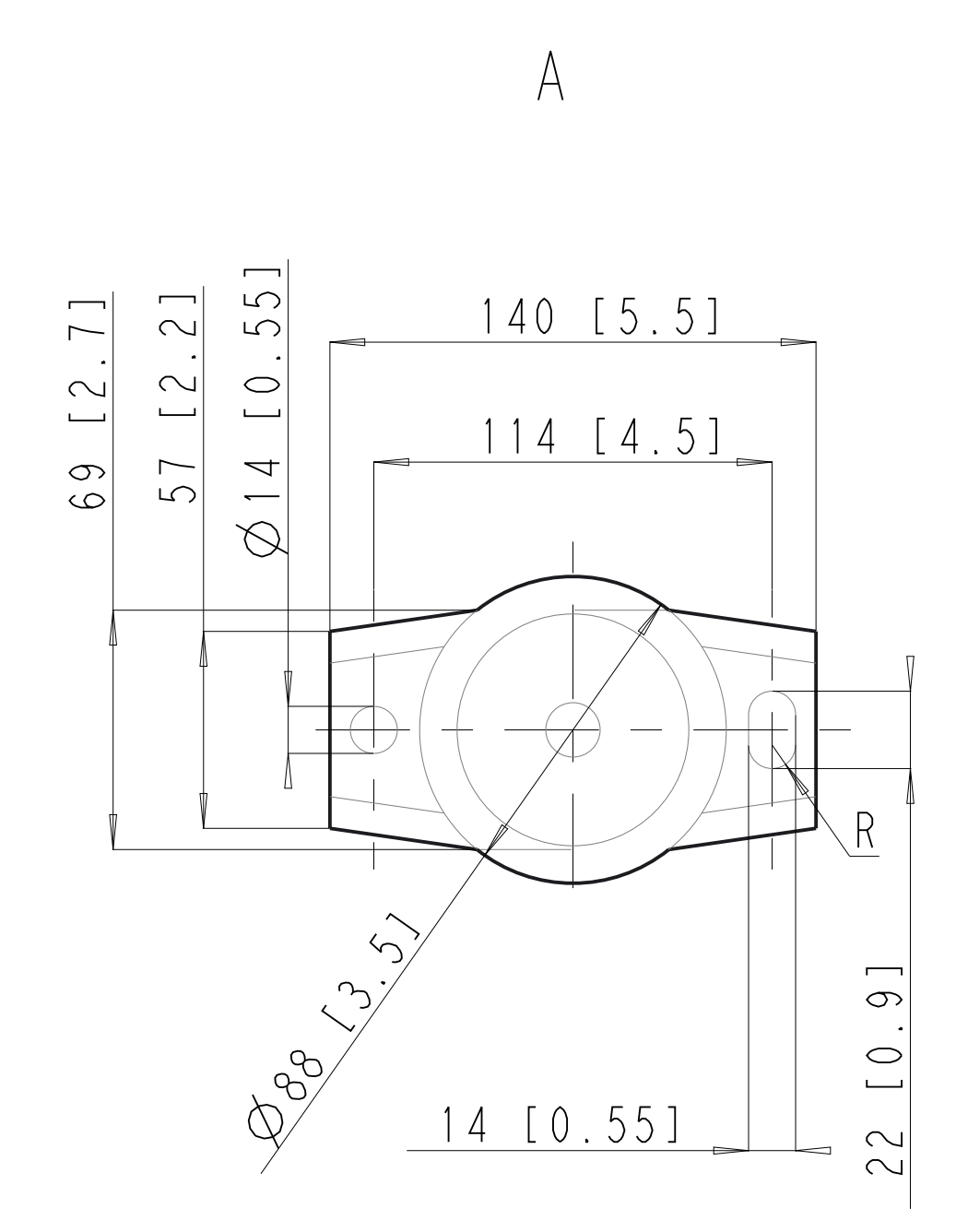

ALTERNATIVE METHOD FOR ENGINE MOUNT:
 PRE-DRILL STRINGERS USING Ø9 [Ø11/32] FOR
 PILOT TO DEPTH EQUIVALENT TO PENETRATION
 OF SCREW AND Ø13 [Ø1/2] C'BORE IF NECESSARY.
 ONLY TO DEPTH REQUIRED TO CLEAR SCREW SHANK.

STRINGERS MAY HAVE TO BE RELIEVED FOR
 EXHAUST PIPE CLEARANCE. 2 PLACES.

RECOMMENDED CLEARANCE
 FOR RAW-WATER
 PUMP MAINTENANCE
 FRONT OF THE ENGINE

SYMBOLS, DESIGNATIONS AND GENERAL DRAWING METHODS STD 101-0005

The copying, distribution and utilization of this document as well as the completion of its contents is allowed only for the specific project to which it applies. Any other use is prohibited. Offenders are liable to the extent of the patent, utility model or trademark design registration.

Document title: **INSTALLATION DRAWING GENV V8, 5.3L**

Document type: **COVER DRAWING**

Document No: **23094940** Issue index: **02** Sheet No: **1(1)**

VOLVO PENTA