

| | X | Y | Z |
|----|-------|------|-----|
| A1 | -530 | -205 | -5 |
| A2 | -570 | -205 | -55 |
| A3 | | | |
| A4 | | | |
| A5 | | | |
| B1 | | | |
| B2 | | | |
| B3 | | | |
| B4 | | | |
| B5 | | | |
| C1 | | | |
| C2 | | | |
| C3 | -955 | -485 | 95 |
| C4 | -1065 | -480 | 250 |
| D1 | | | |
| D2 | | | |
| D3 | | | |
| E1 | -460 | 260 | 15 |
| E2 | -380 | 305 | 60 |
| E3 | | | |
| E4 | | | |
| E5 | | | |
| E6 | | | |
| E7 | | | |
| E8 | | | |
| E9 | | | |
| F1 | | | |
| G1 | | | |
| G2 | | | |
| H1 | 165 | 90 | 560 |
| H2 | 165 | -40 | 510 |
| H3 | 180 | -35 | 565 |
| H4 | | | |
| K1 | | | |
| M1 | | | |
| M2 | 50 | 350 | 630 |
| M3 | -130 | 440 | 560 |
| N1 | -145 | -430 | 195 |
| N2 | -55 | -400 | 150 |

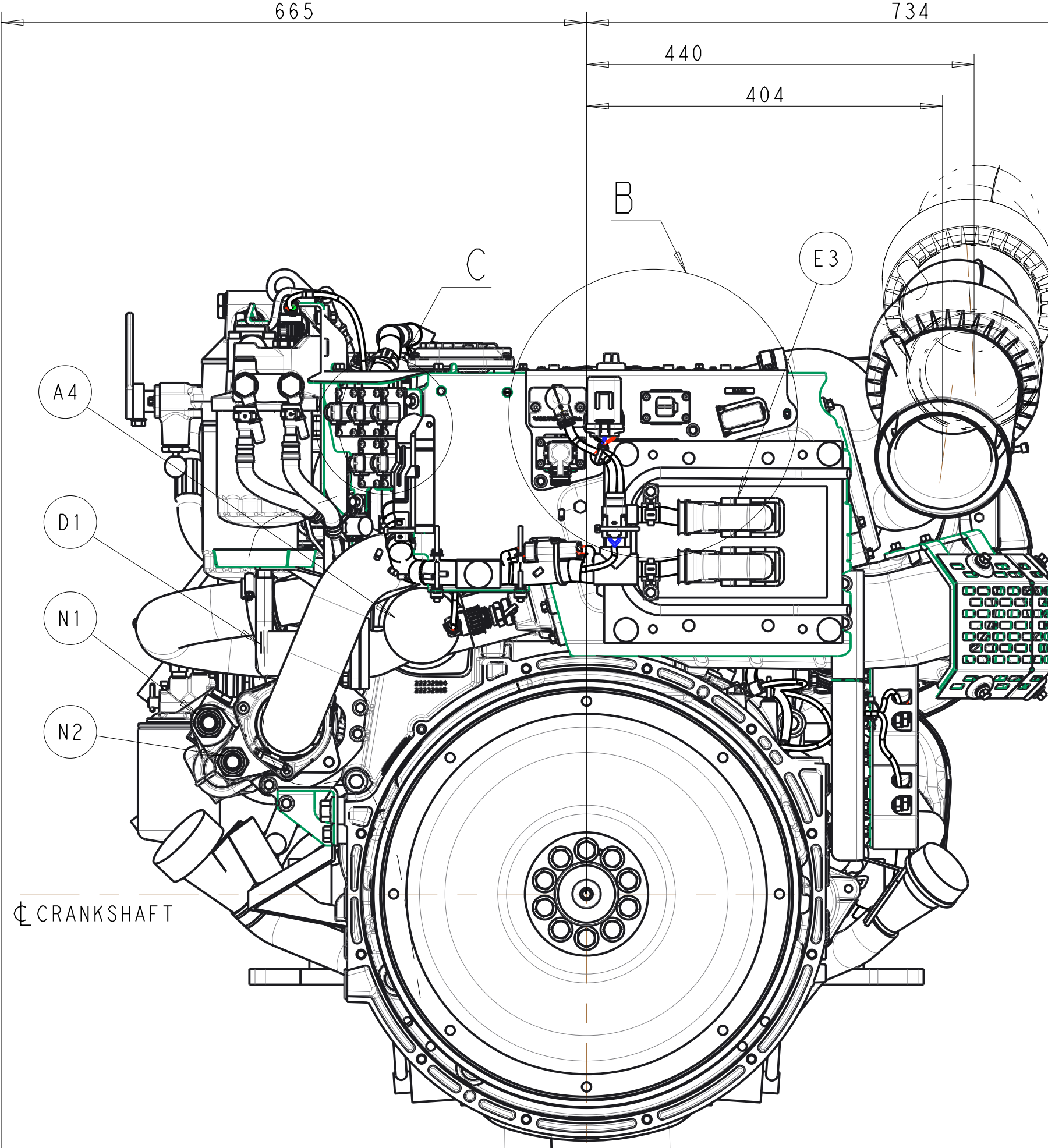
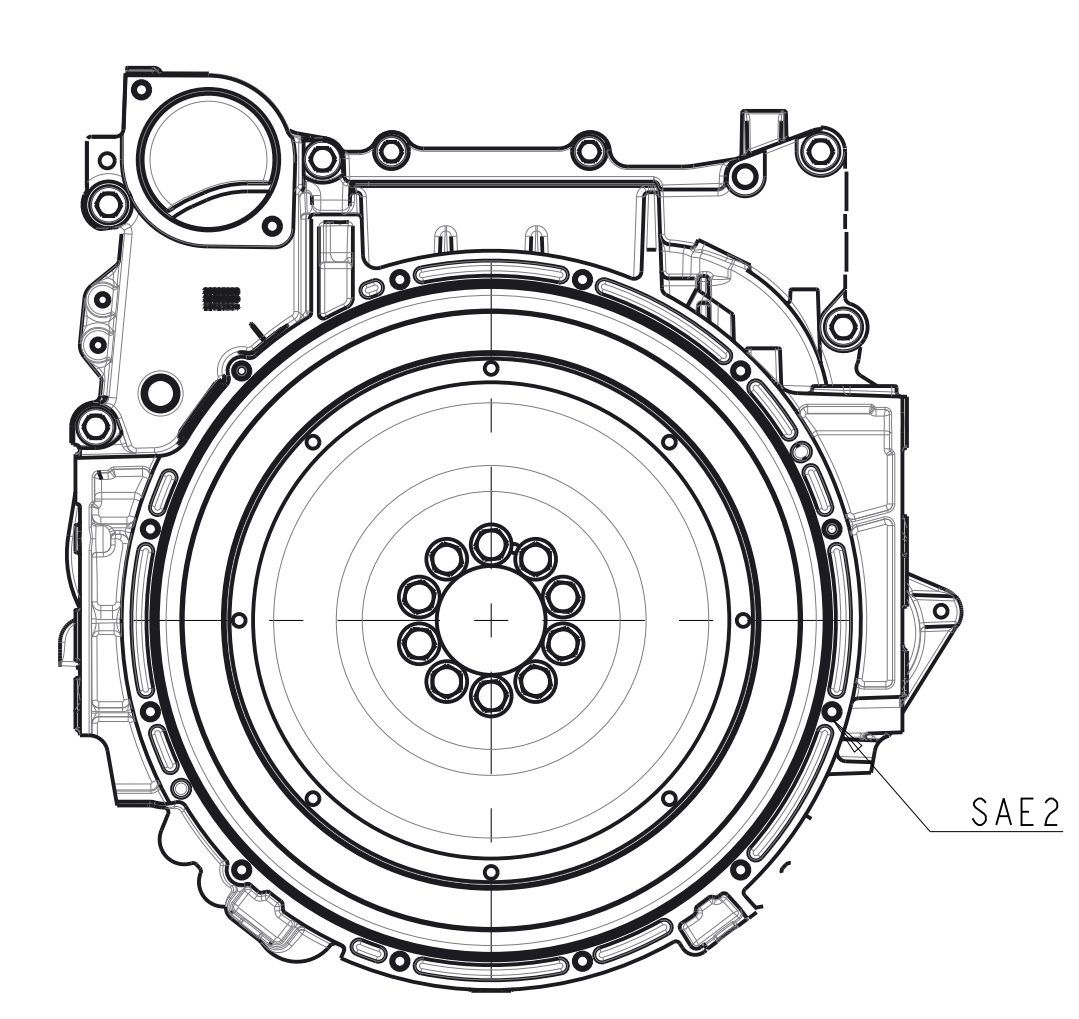
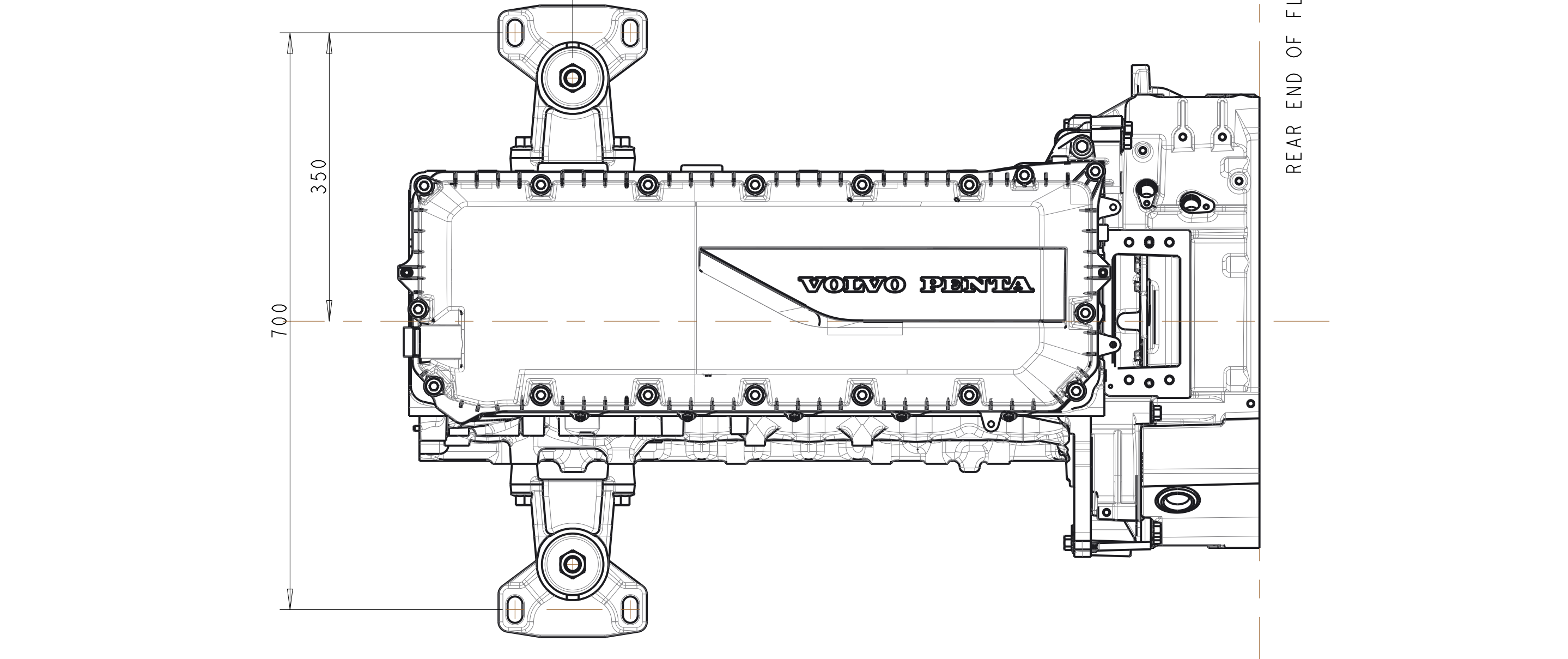

FOR TOLERANCE ON MEASURES PLEASE CONTACT VOLVO PENTA
 (1) RISER OPTION FOR D9 REPOWERING
 (2) WATER LEVEL AT MAXIMUM REGULATED LOAD
 SCALE 1:5