

CARDAN LENGTH D	E	F
STD 370±15mm	816±15	895±15
700-800mm	1146-1246	1225-1325
1100-1200mm	1546-1646	1625-1725
1500-1600mm	1946-2046	2025-2125
1900-2000mm	2346-2446	2425-2525
2400-2500mm	2846-2946	2925-3025

A°	B	C
5	739	674
6	747	659
7	756	644
8	765	628
9	774	611
10	784	594
11	794	577
12	804	559
13	814	540
14	825	521
15	836	501
16	847	481
17	859	459
18	871	438
19	883	415
20	896	392
21	909	369
22	923	344
23	937	319
24	951	293

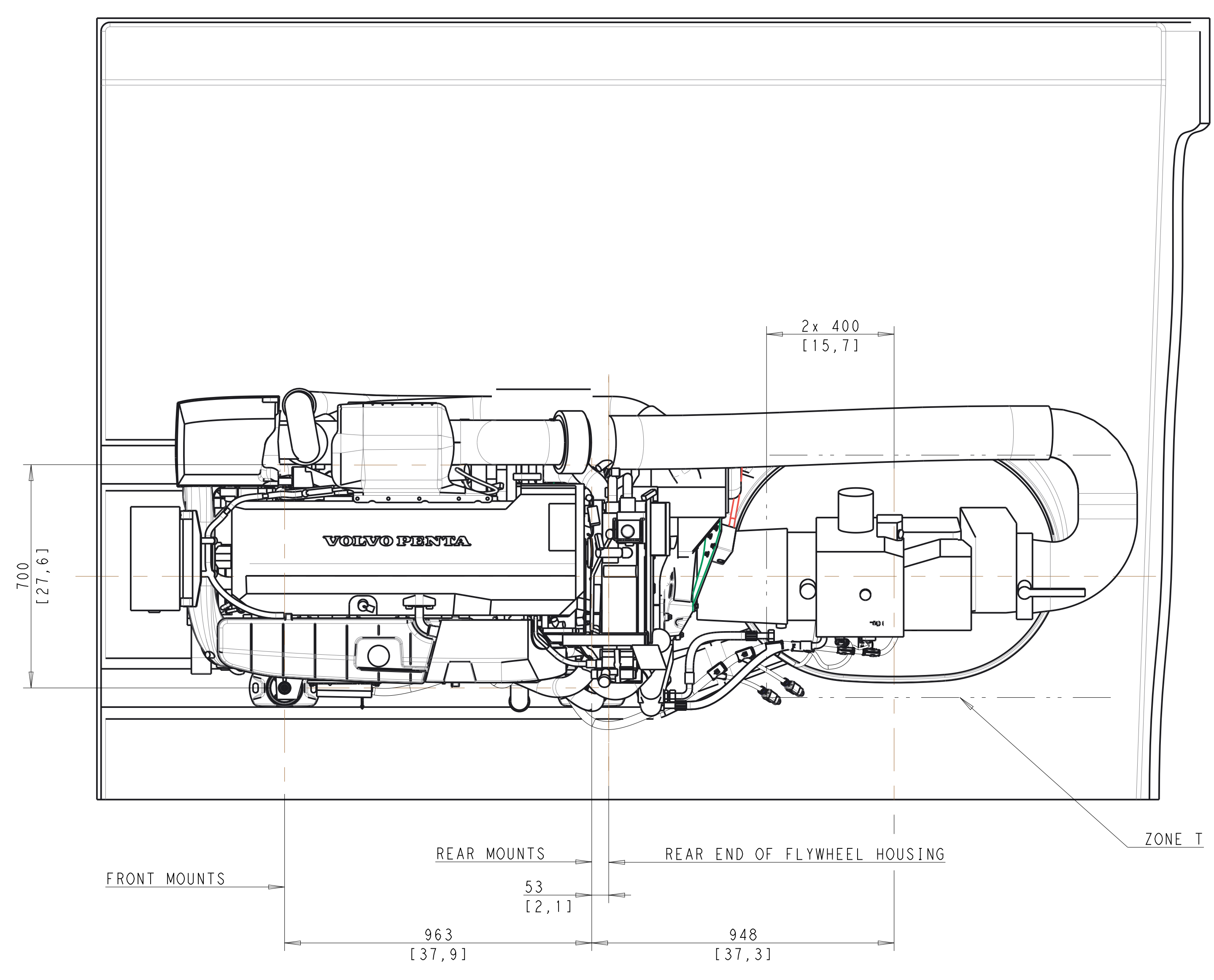

IPS UNIT	
K	OIL DRAIN (2x)
J	CONNECTION RPM SENDER
H	CONNECTION ELECTRICAL CONTROL
G	CONNECTION BATTERY POS. AND NEG.
F	CONNECTION OIL TEMP. / PRESSURE
E	CONNECTION, SHIFT SOLENOIDS
D	OIL DIPSTICK GEAR BOX
C	OIL FILLER GEAR BOX

FOR EASY INSTALLATION, USE ENGINE/IPS BED INSTALLATION TOOL

ENGINE

THIS DRAWING IS A COMPLEMENT TO DIMENSION DRAWING 22754398

SCALE 1:10

SYMBOLS, DESIGNATIONS AND GENERAL DRAWING METHODS STD 101-0005

The copying, distribution and utilization of this document as well as the completion of its contents is allowed without restriction in the event of a purchase of the product. All other rights reserved to the extent of the patent, utility model or trademark design registration.

Document title: ENGINE INSTALLATION IPS 2 WITH D11

Document type: INSTALLATION DRAWING

Document No: 22754405 Issue Index: 02 Sheet No: 1(1)