

TOP

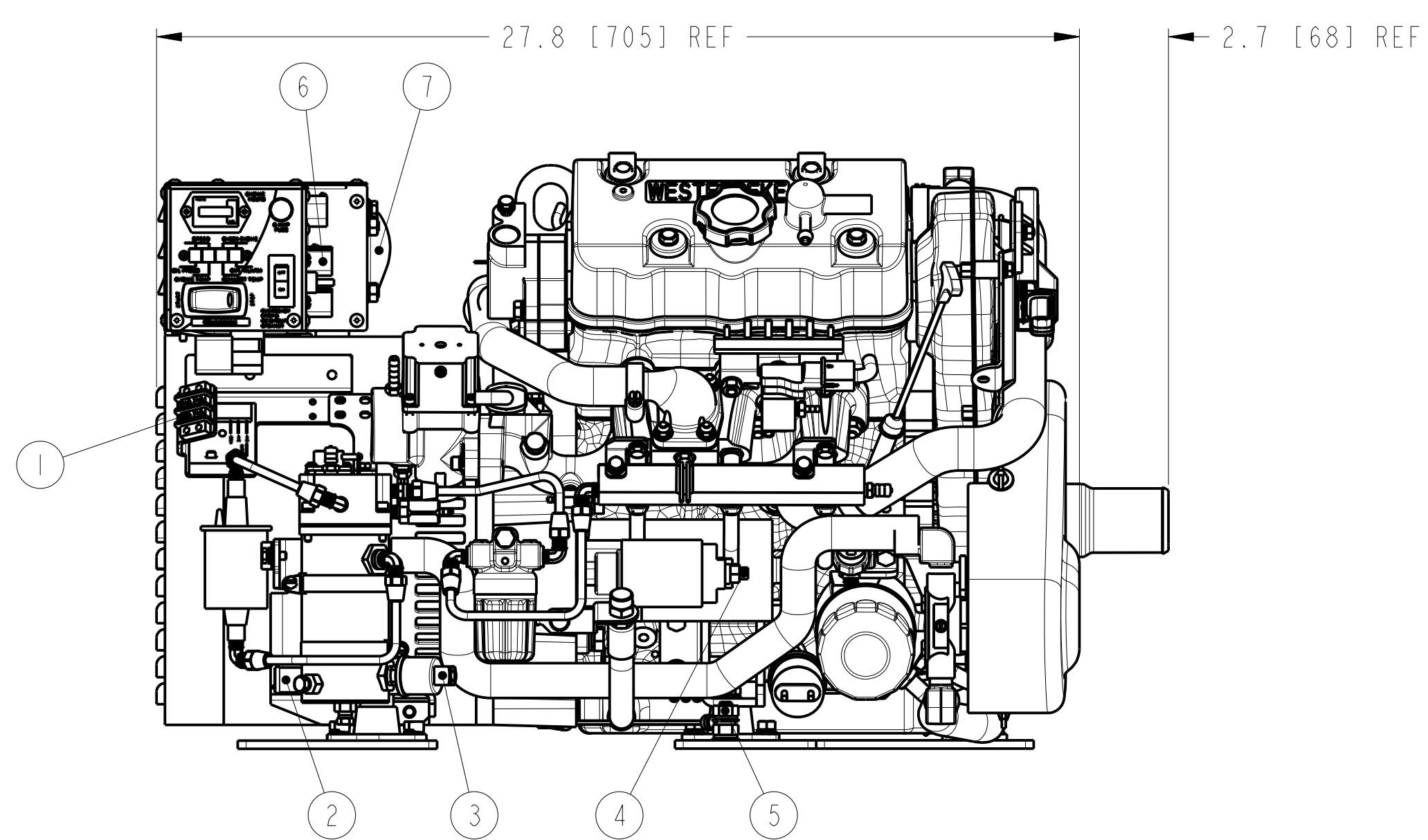

SERVICE SIDE

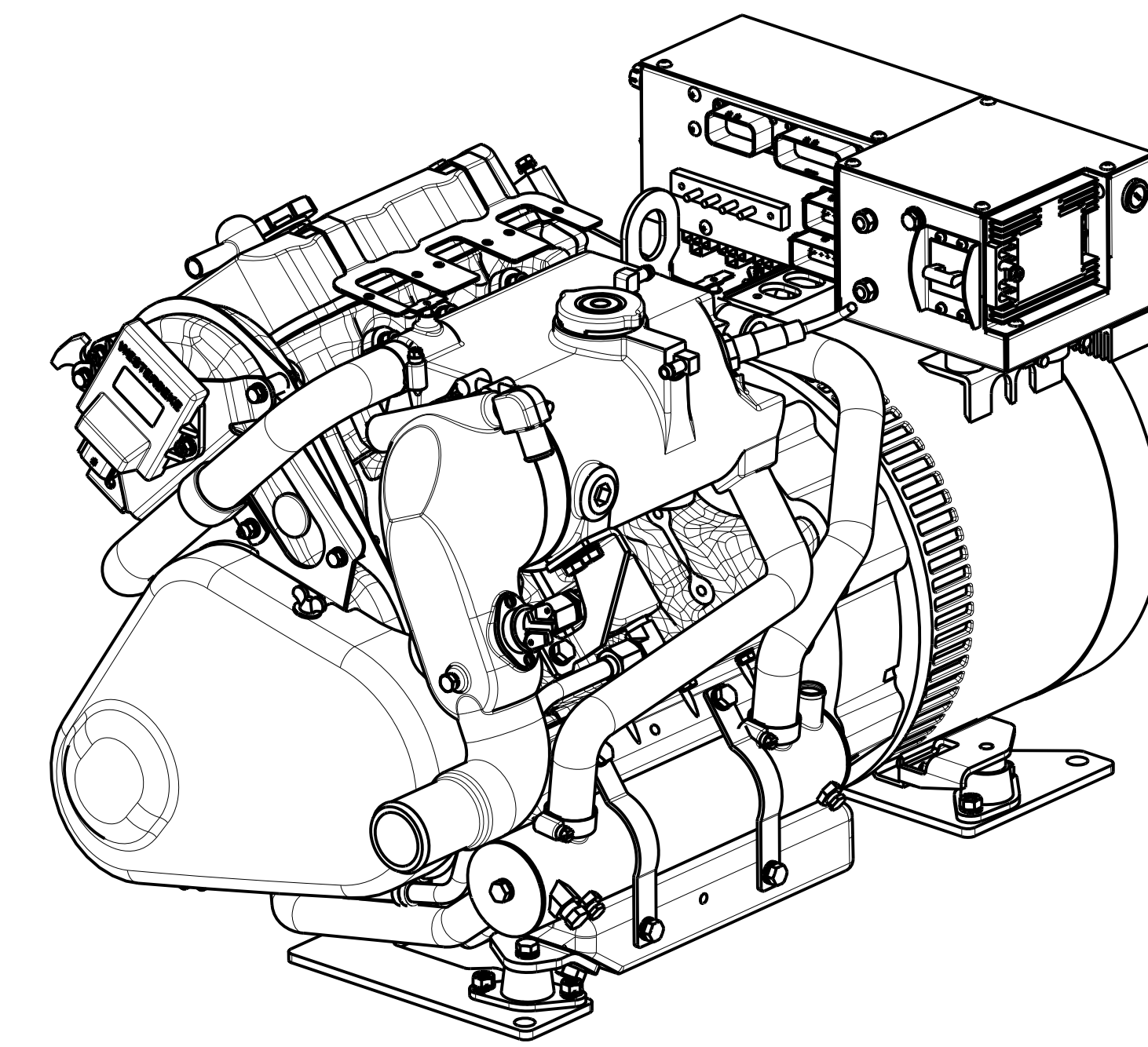
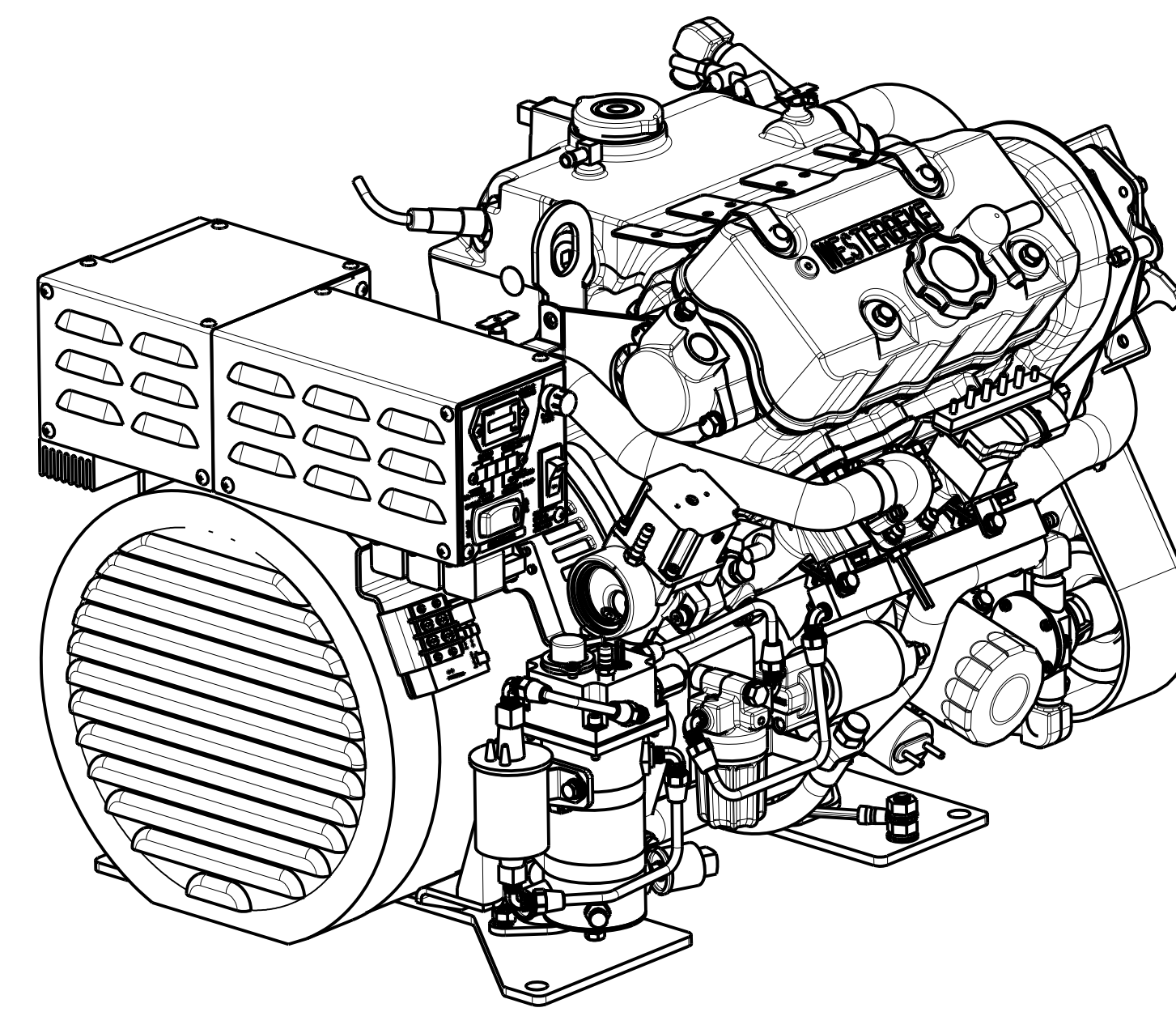
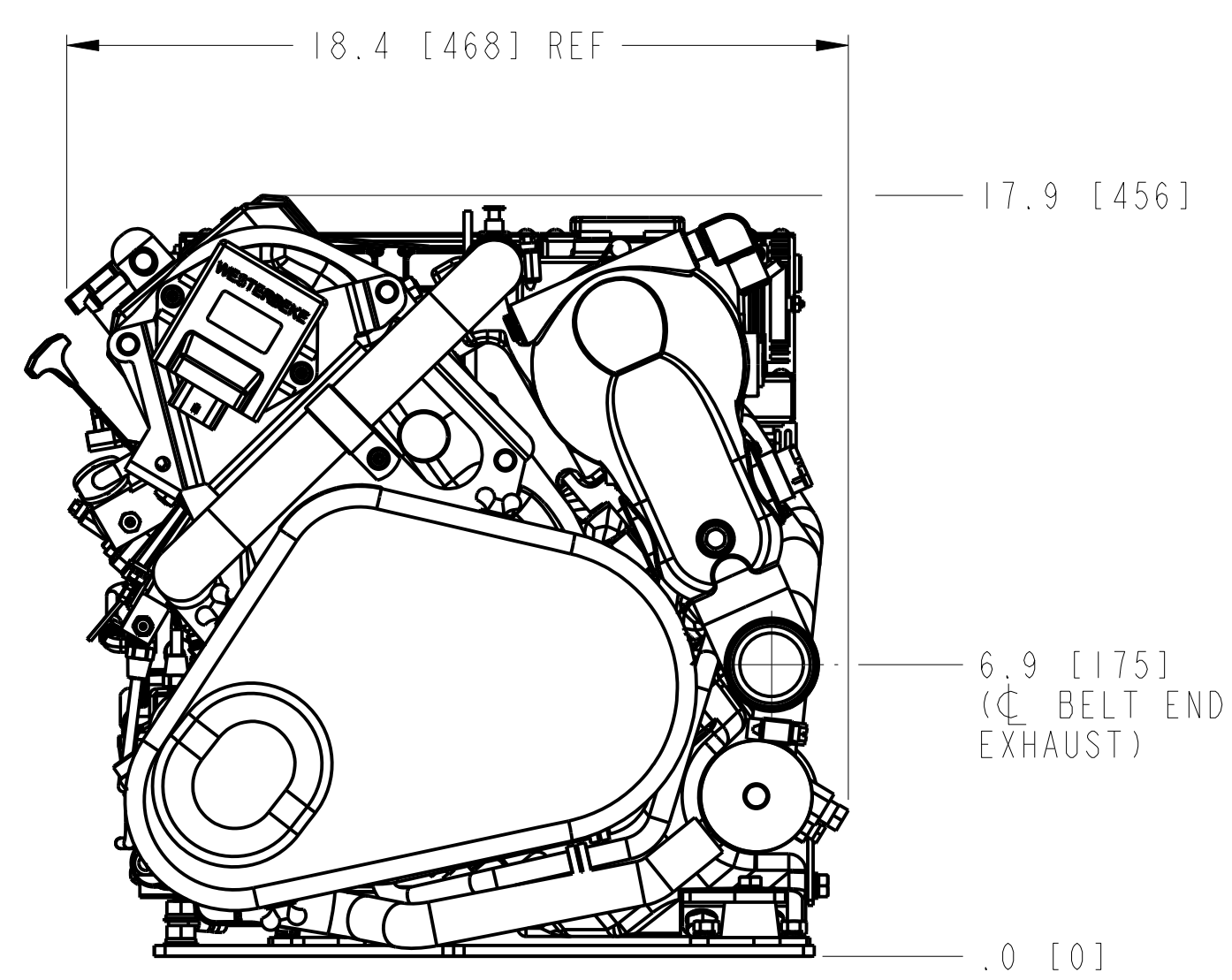

BELT END

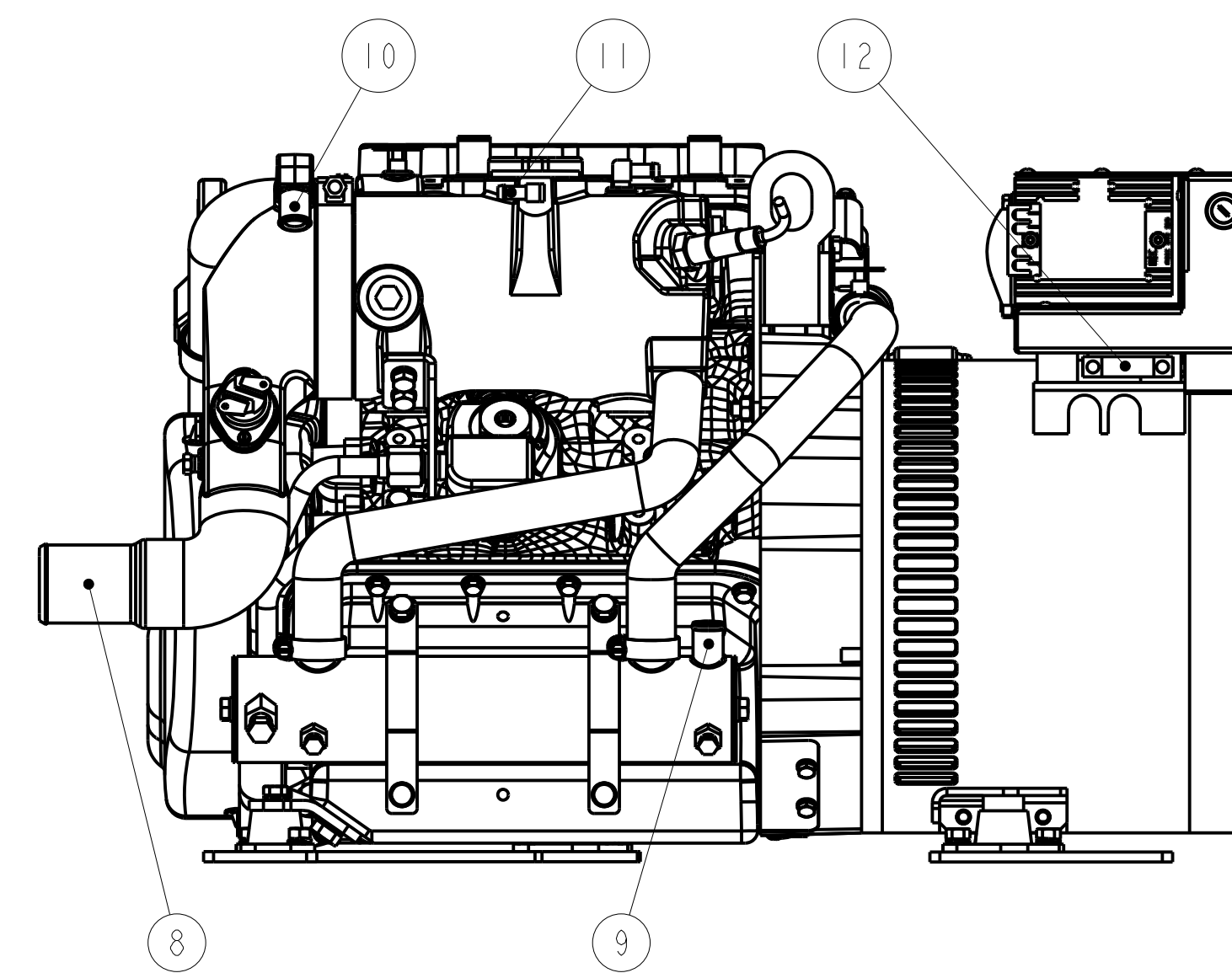

NON-SERVICE SIDE

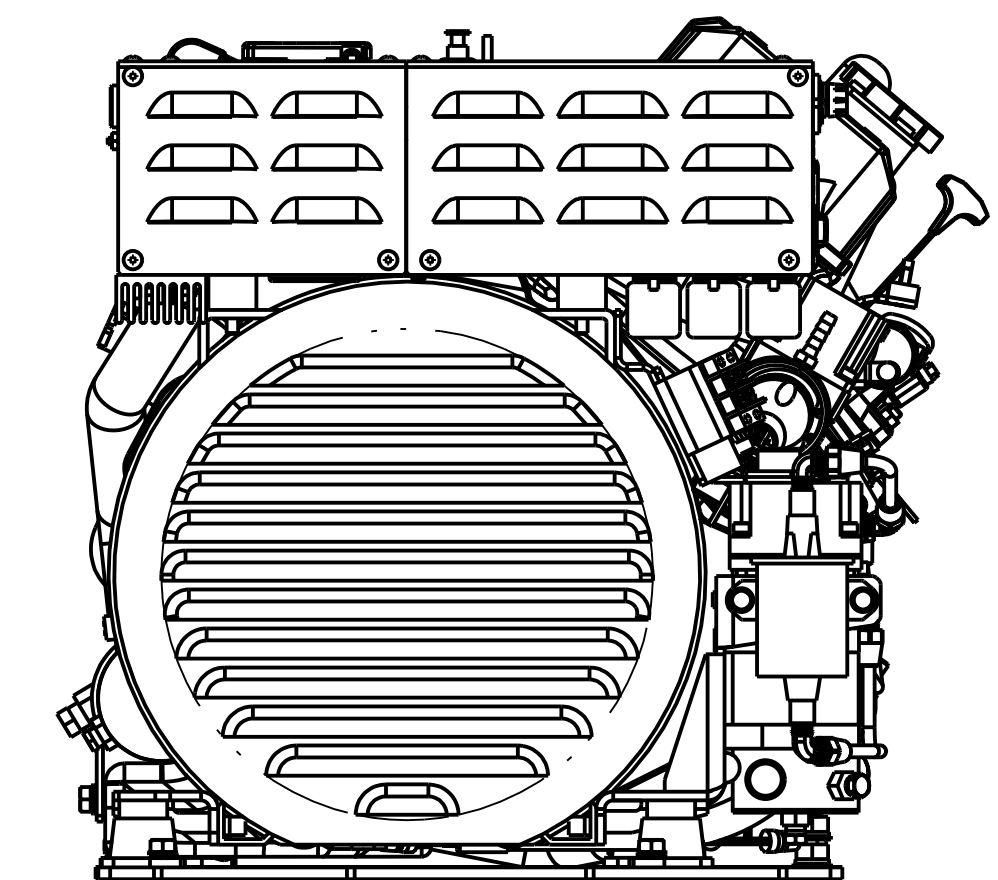

GENERATOR END

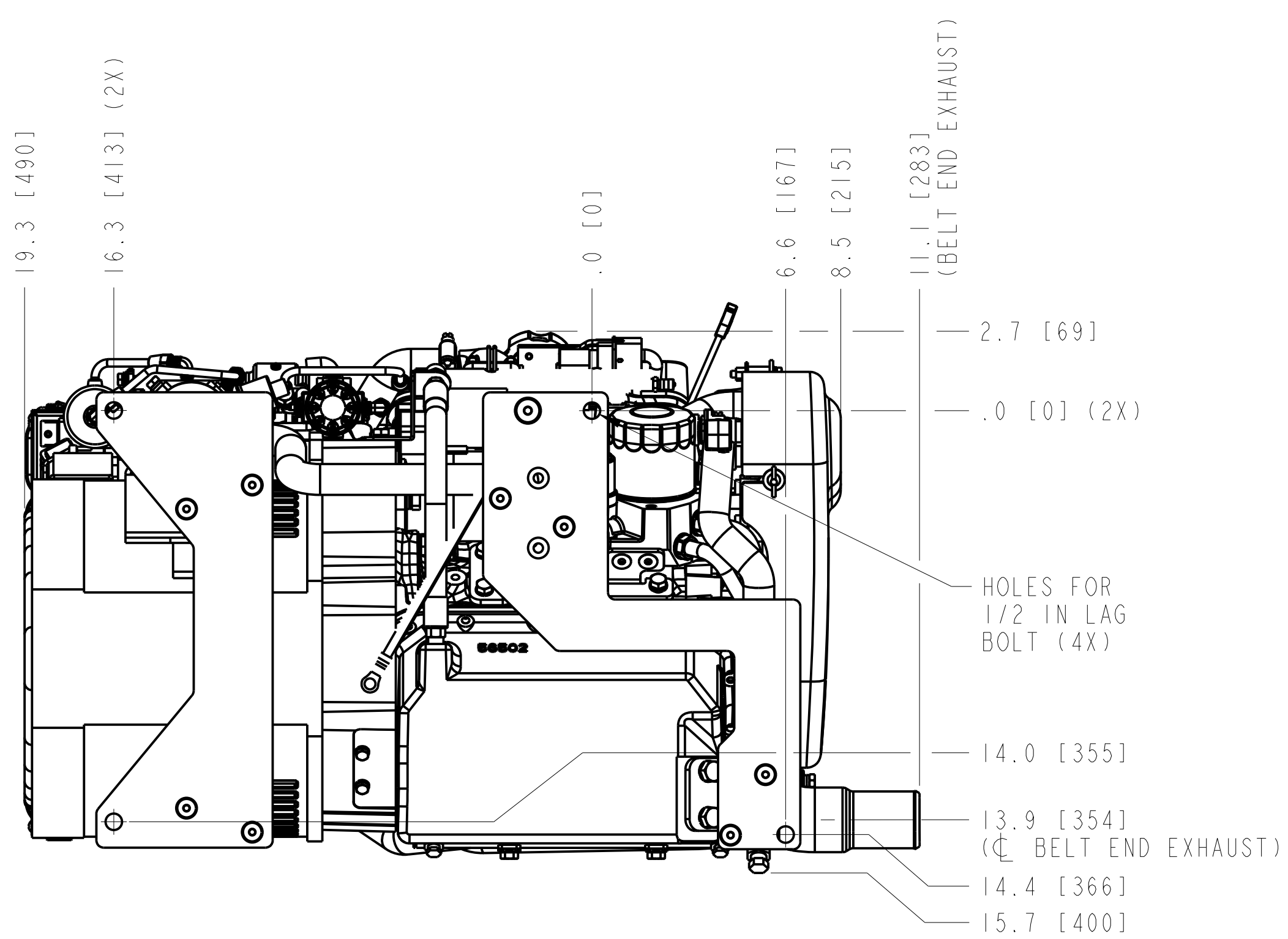

BOTTOM

ITEM	CONNECTIONS
1	FIRE BOY
2	RAW WATER INLET, REQUIRES 3/4 IN ID HOSE TO CONNECT
3	FUEL LINE, REQUIRES 1/8-27 NPT MALE TO CONNECT
4	BATTERY (POS)
5	BATTERY (NEG)
6	REMOTE PANEL
7	A/C CIRCUIT BREAKER
8	WET EXHAUST, REQUIRES 2 IN ID HOSE TO CONNECT
9	RAW WATER OUTLET (TO SIPHON BREAK), REQUIRES 3/4 IN ID HOSE TO CONNECT
10	RAW WATER INLET (FROM SIPHON BREAK), REQUIRES 3/4 IN ID HOSE TO CONNECT
11	COOLANT OVERFLOW, REQUIRES 5/16 IN ID HOSE TO CONNECT
12	AC POWER

NOTES (UNLESS OTHERWISE SPECIFIED)
 1. UNIT OF DIMENSIONS: INCH [MM]
 2. TOLERANCE: ±.375 [9.5]

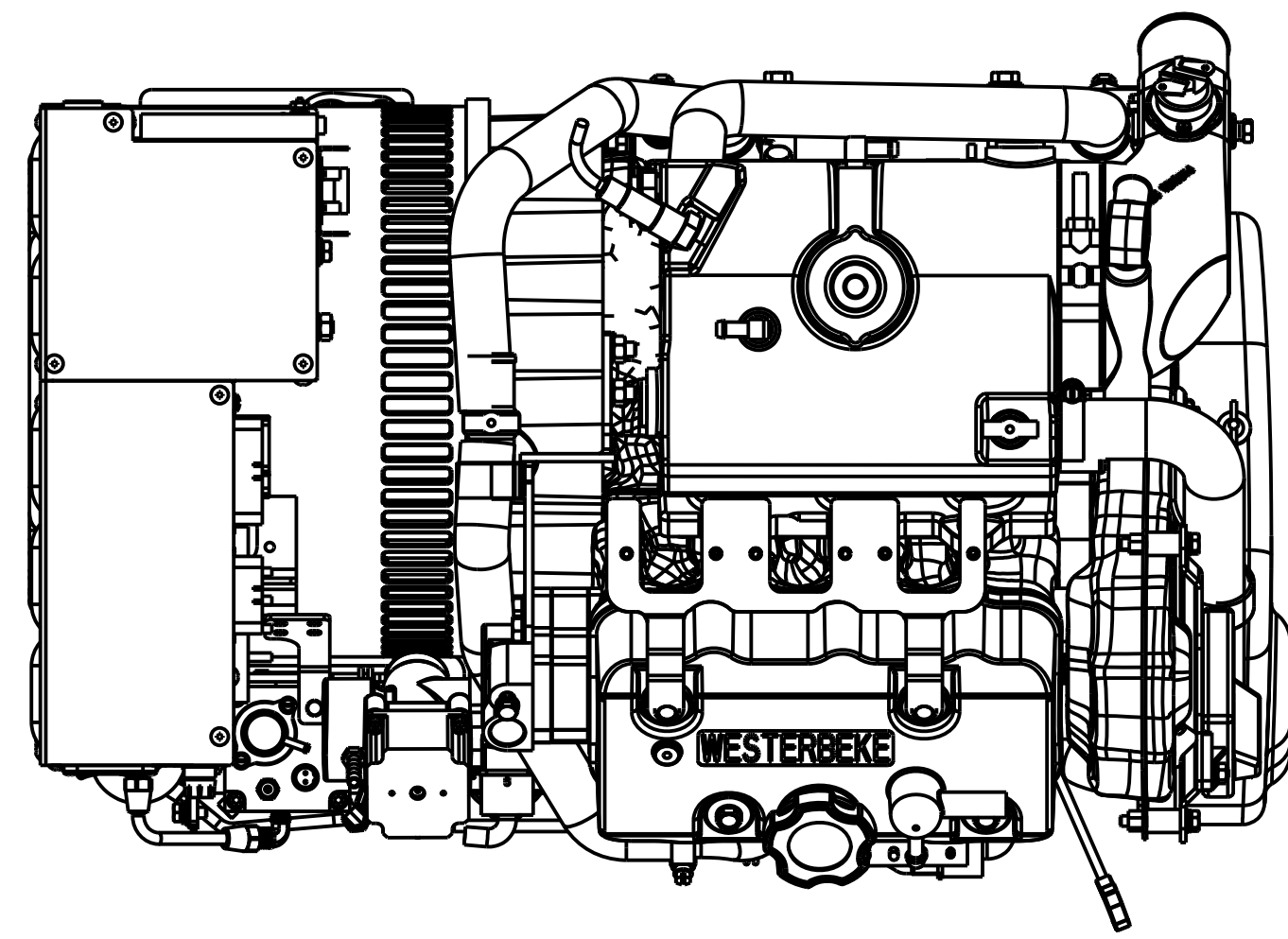

TOP

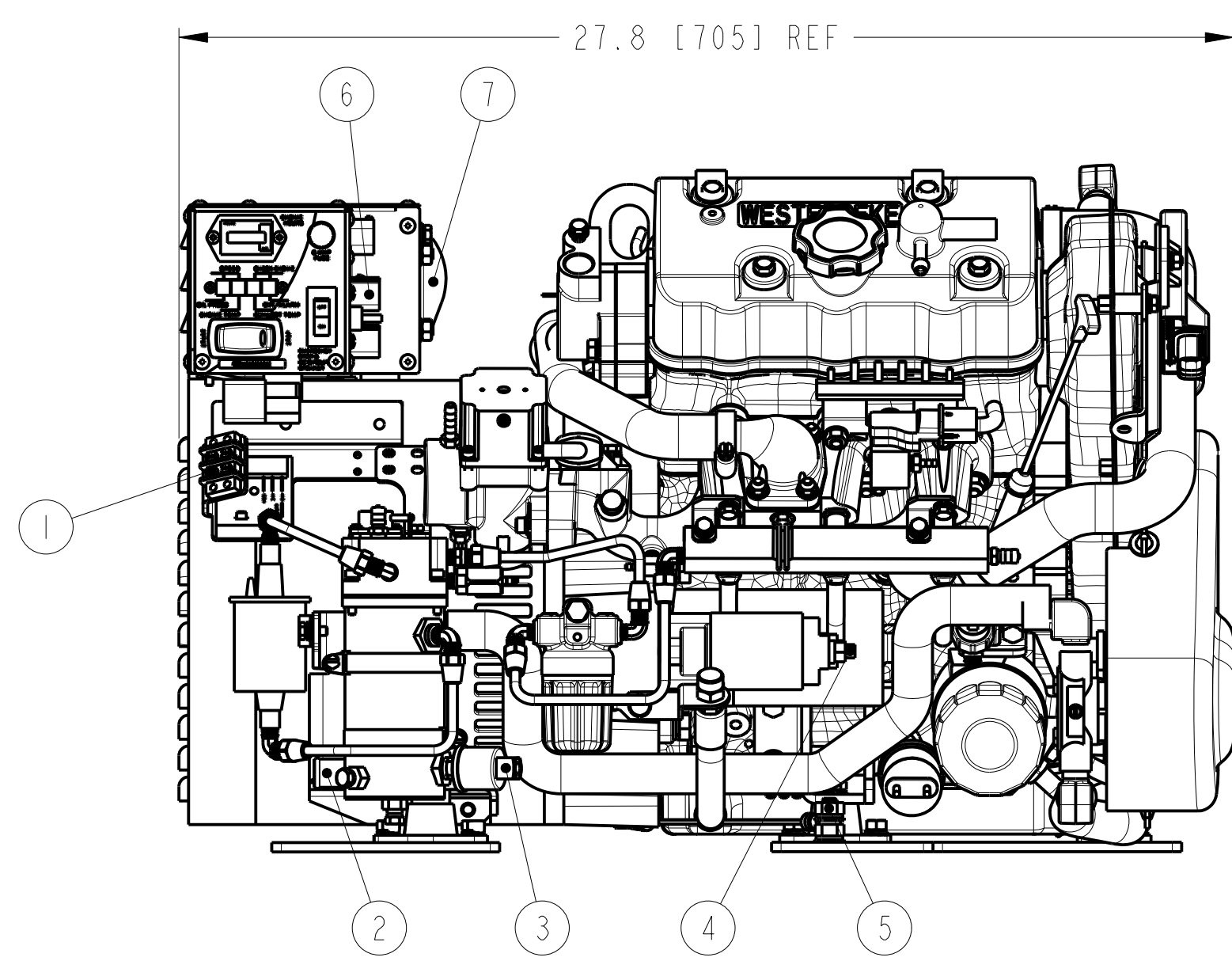
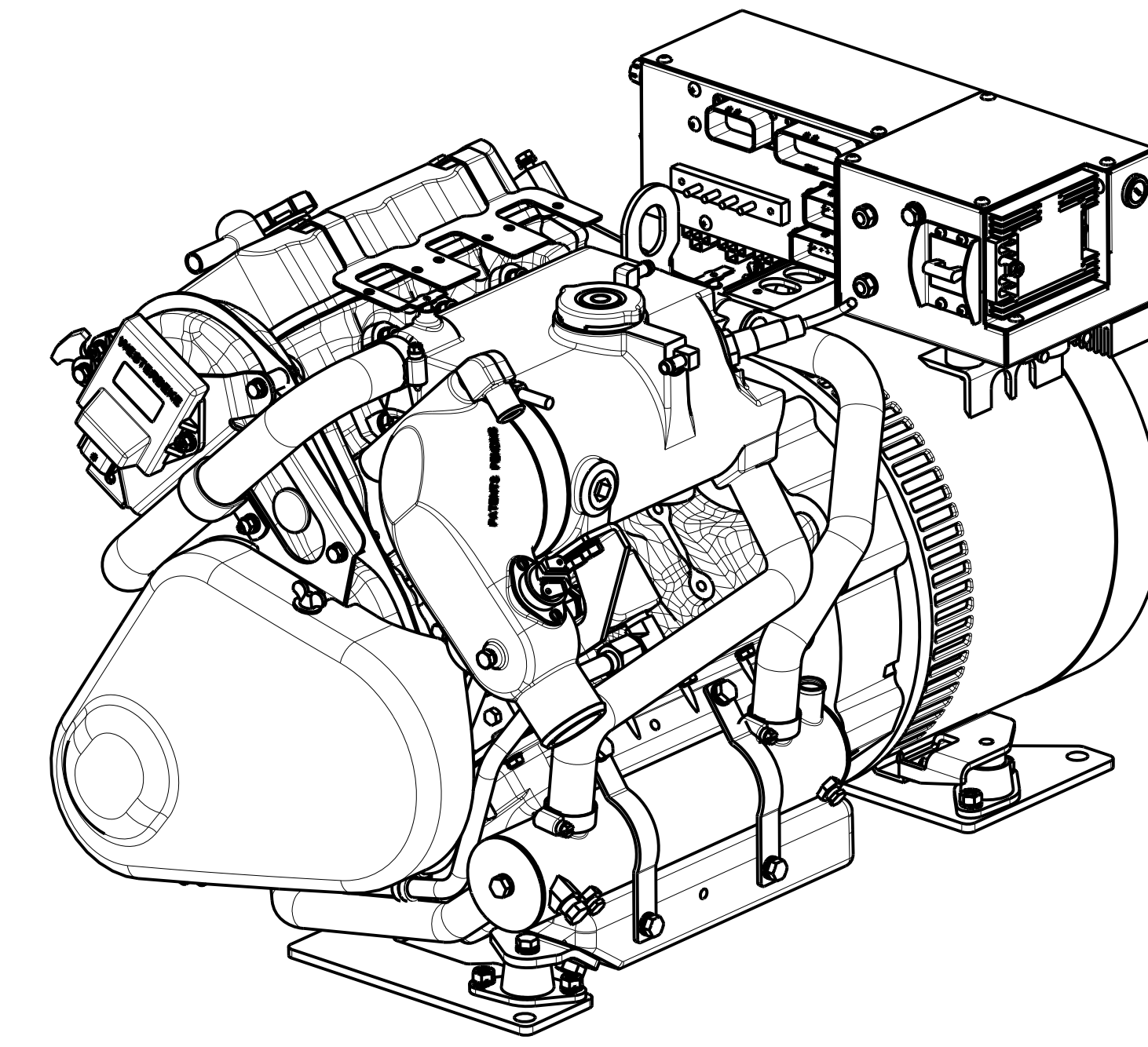
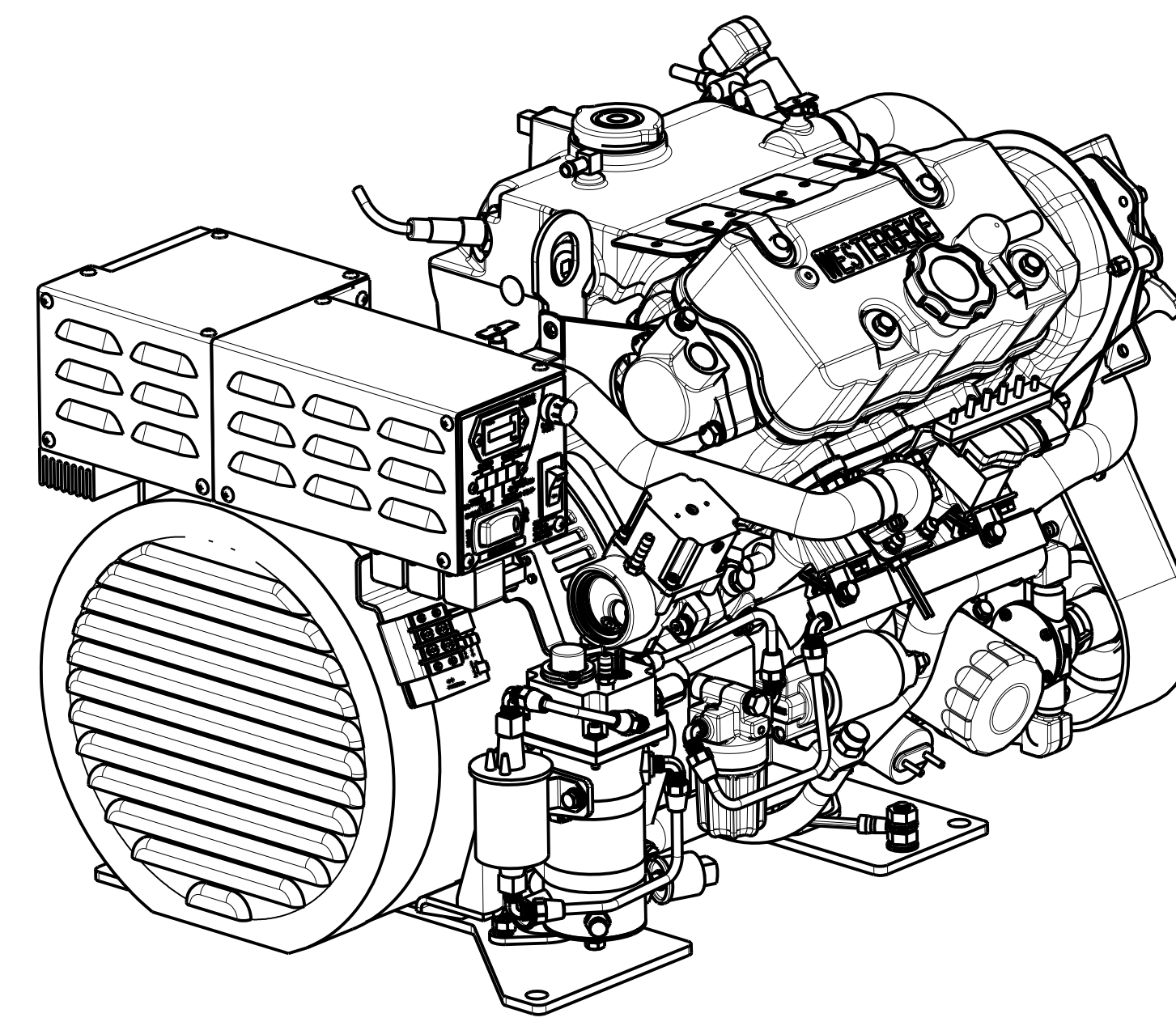

SERVICE SIDE

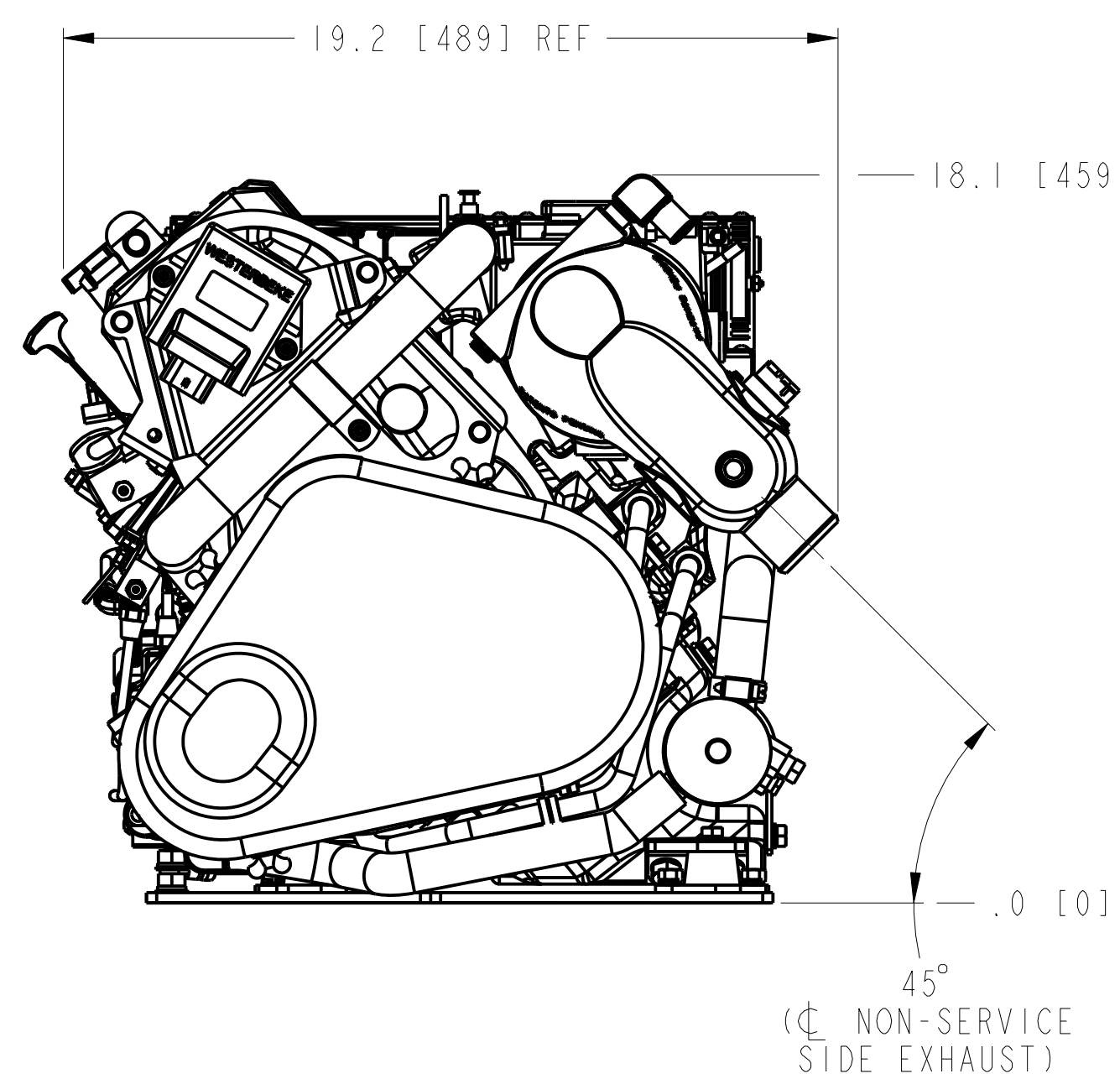

BELT END

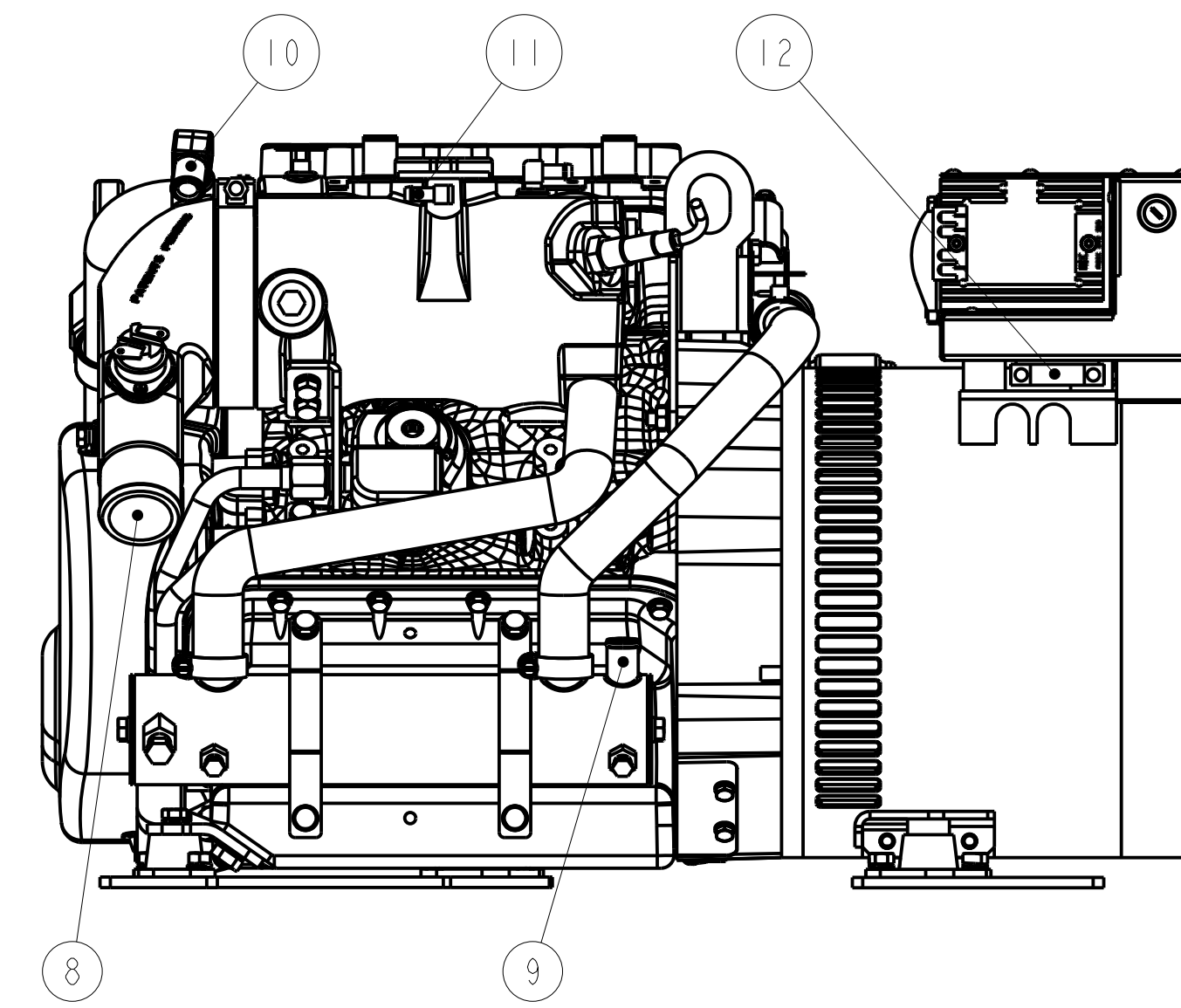

NON-SERVICE SIDE

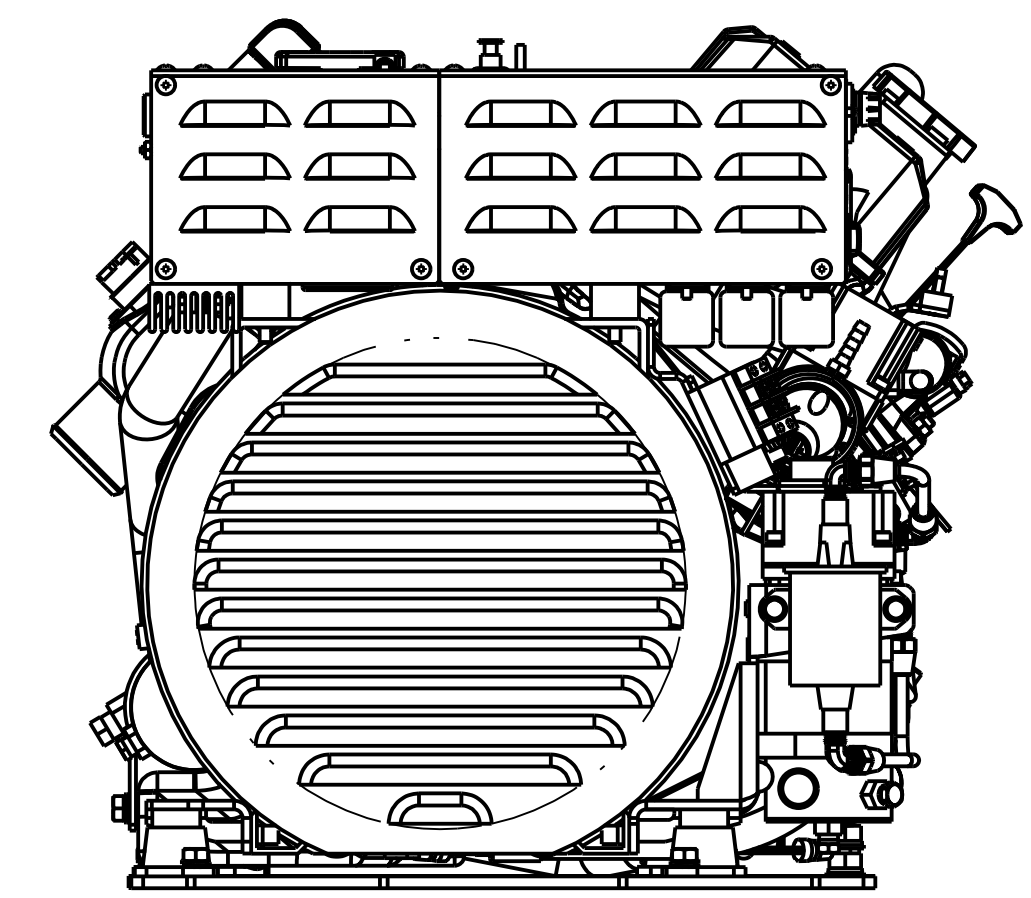

GENERATOR END

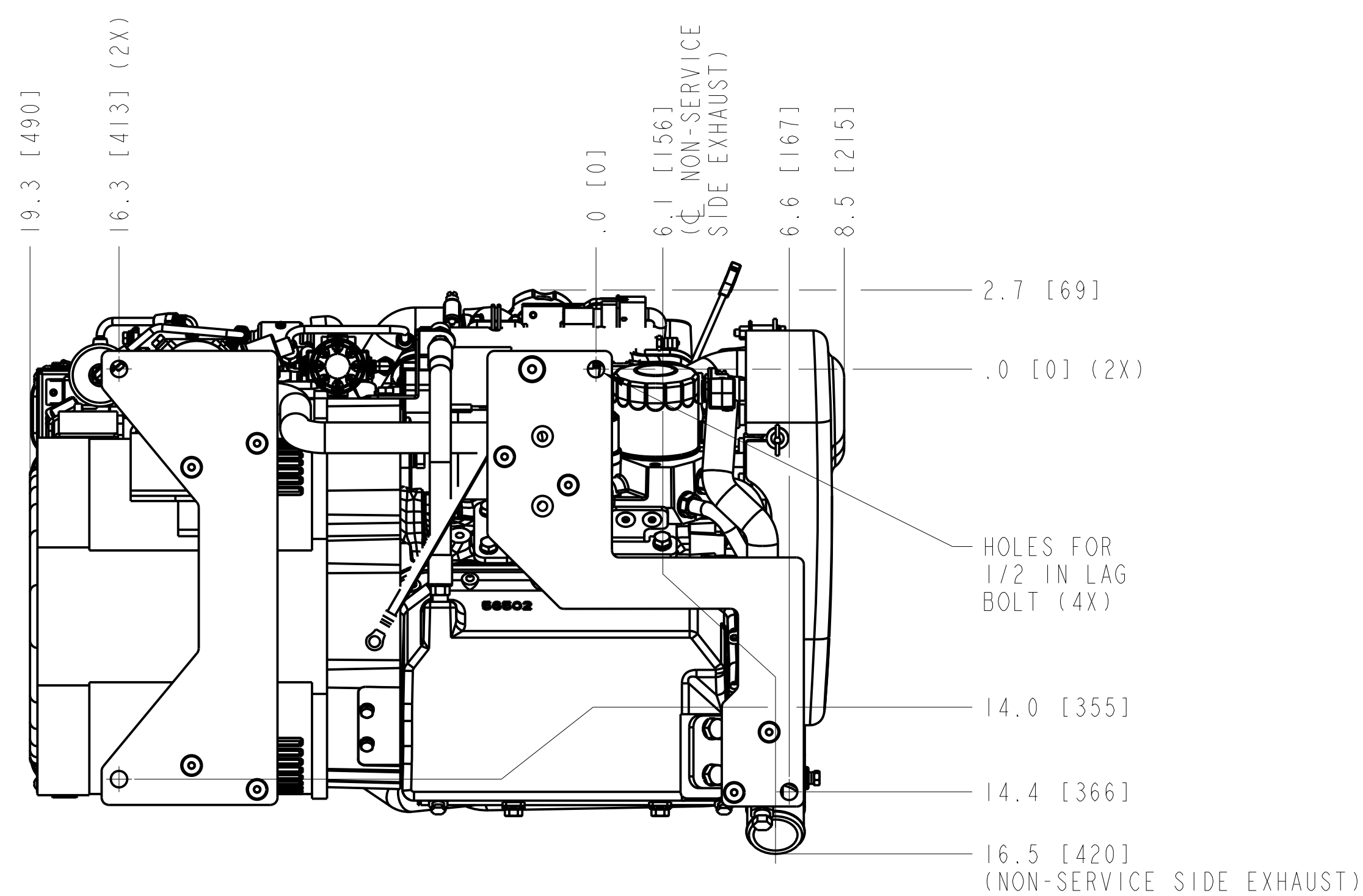

BOTTOM

ITEM	CONNECTIONS
1	FIRE BOY
2	RAW WATER INLET, REQUIRES 3/4 IN ID HOSE TO CONNECT
3	FUEL LINE, REQUIRES 1/8-27 NPT MALE TO CONNECT
4	BATTERY (POS)
5	BATTERY (NEG)
6	REMOTE PANEL
7	A/C CIRCUIT BREAKER
8	WET EXHAUST, REQUIRES 2 IN ID HOSE TO CONNECT
9	RAW WATER OUTLET (TO SIPHON BREAK), REQUIRES 3/4 IN ID HOSE TO CONNECT
10	RAW WATER INLET (FROM SIPHON BREAK), REQUIRES 3/4 IN ID HOSE TO CONNECT
11	COOLANT OVERFLOW, REQUIRES 5/16 IN ID HOSE TO CONNECT
12	AC POWER

NOTES (UNLESS OTHERWISE SPECIFIED):
 1. UNIT OF DIMENSIONS: INCH [MM]
 2. TOLERANCE: ±.375 [9.5]

WESTERBEKE CORPORATION
 TAUNTON, MA 02780

TITLE
 DG1INSTALL 7.5/6.2 MCGA,
 NON-SERVICE SIDE EXHAUST CONNECTION

DRAWN BY: RH DATE: JUN-18-18 MATERIAL:

APPROVED BY: DATE:

SCALE: 1/4 SIZE: DRAWING NUMBER: REV:

SHT. 2 OF 2 E 56572